

QUICK BLOCK

QUICKER • LESS EXPENSIVE • LONGER LASTING • STANDARDIZATION



Ensure Consistent Standards

- Designed to evenly distribute weight
- No labour costs building wood blocks
- Interlock for multiple feed installation
- Tested at extreme weight & temperature
- Eliminate the hassles of supporting equipment feeds on a flat roof

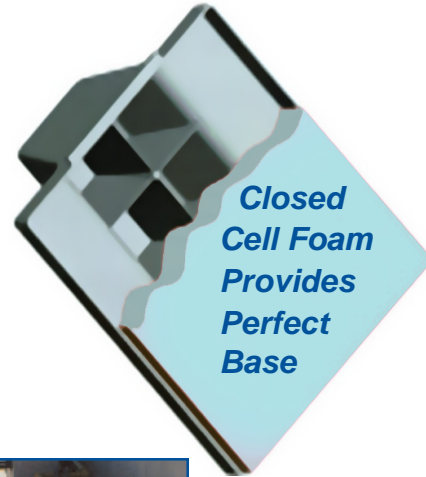

Closed Cell Foam Provides Perfect Base



Eliminate Poor Workmanship & Costly Roof Repairs



Extension Kits for all Applications

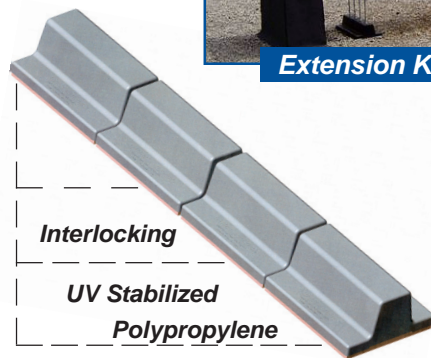

Interlocking

UV Stabilized Polypropylene



- Available at local wholesalers
- Limited Lifetime Warranty

SPECIFICATIONS

Product Description

The Quick Block is designed to replace the current practice by skilled trades people of building wooden blocks for support of vital mechanical infrastructure on flat roofs including:

- gas pipe
- electrical conduit
- refrigeration piping

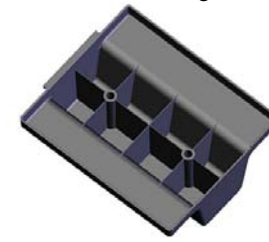

The roof block is an assembled product comprised of two major components including the support shell which is an one piece, UV resistant, thermoplastic injection molded Polypropylene Impact Copolymer and the Type 3, 20 psi extruded polystyrene non-marring base. The support shell (shown left, inverted without base) is designed with an interior web creating eight symmetrical cavities. Design maximizes support strength while substantially reducing the overall weight. Interior cavities allow for expansion and contraction under extreme temperature conditions over its lifetime. The lower portion of the one-piece support shell incorporates a 3/4" high wall which reduces UV exposure to the extruded polystyrene base.

Typical Physical Properties of Non-Marring Base (OC Canada – Type III, CAN/ULC- S701 - 97)

Thermal Resistance (Ft ² hr °F/B T U) (m ² °C/W)	Compressive Strength, min (psi) (kpa)	Water Absorption, max. (% by volume)	Water Vapour Permeance, max. (perms) (ng/Pa.s.m ²)	Water Capillarity	Water Affinity	Flexural Strength, typical (psi) (kpa)	Max. Operating Temperature (°F) (°C)
5.0	20	0.70	0.85	None	Hydrophobic	44	165
0.87	140		49			300	74

Compression Testing - Refer to ASTM - D1708-02a Standard Test Method for Tensile Properties of Plastics

Base: 13 3/4" square 1/4" square steel plate on Pedestal post

Crosshead/Arm Probe: 5 1/2" diameter x 5/8" thick machined disk on post - roof block located on centerlines between the machine frame

Machine Mode: general compression

Crosshead travel speed: 0.10" per minute

Maximum load setting: 1,200 pounds - no product failure

Maximum deflection: 0.50 inches

Temperature/Humidity: 73°F/50%

Output report settings: pounds of compressive load vs inches deflection (Note: output can be displayed in many other settings such as stress vs strain)

The block sustained compression with no mechanical fracture up to the maximum limits of the test (1200 pounds). The extruded polystyrene base absorbed much of the load and was the primary (maybe only) cause for deflection. The mechanical compression was spread through the 5 1/2" disk that contacted the mounting area in the centre of the block (14.84 in² of contact surface).

Pull Test - Refer to ASTM - D2990-01 Standard Test Methods for Tensile, Compressive, Flexural Creep and Rupture of Plastics

The test revealed the best-case scenario for installation of the 2-hole galvanized pipe straps, mounted to the roof block using fasteners available locally. The test data suggests that the most coarse thread and largest diameter head type screws should be used for ideal installation. The installer may use the type of screw best for their specific application, *although a coarse screw with a large head diameter will maximize retention.*

Screw Type	Force	Test #1	Test #2	Test #1	Test #2	Test #1	Test #2	Average	Geomean
		2.5" horseshoe clamp	2.0" horseshoe clamp	2.0" horseshoe clamp	2.0" horseshoe clamp	1.5" horseshoe clamp	1.5" horseshoe clamp		
Sheet Metal		319.27	279.47	242.46	308.18	460.97	282.66	315.50	308.90
#14-10	Extension @ break	0.656	0.600	0.441	0.467	0.790	0.421	0.563	0.55

Special Notes:

- ① Roller extension kits available for raising/sloping pipe
- ② Strut extension kits available for conduit installation
- ③ Custom foams and bases available for all applications
- ④ Custom support solutions available (contact manufacturer)

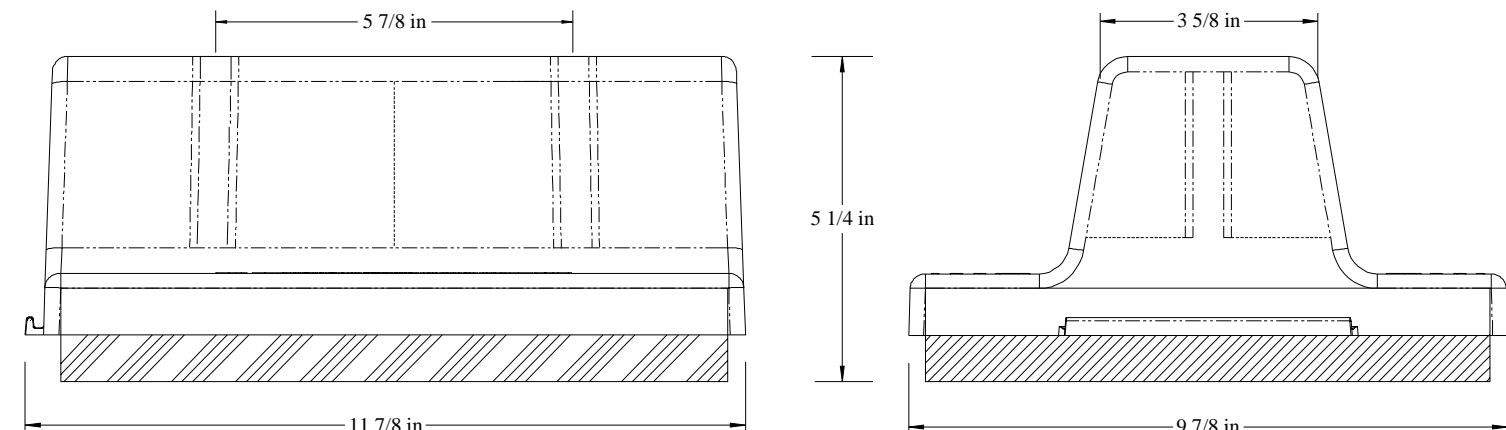

PIPE-EASE INC.

PO Box 25412
 London Ontario N6C 6B1
Telephone: (519) 854-0411
Toll Free Fax: (866) 753-2880

Distributed by: